

Improving the Uncertainty of Dc Current Measurements

Kai Wendler, Roberto Roca Profet, Keil Gallinger, Kyle Coleman, and Alessio Pollarolo

Abstract

The accurate measurement of dc current from 1 A to 3000 A is of interest in many fields, including metrology, power generation, and multiple industries. Current measurement is often performed using Hall sensors, Anisotropic Magneto-Resistive (AMR) sensors, and dc resistance shunts. Each of these devices have limitations and all require calibration to provide traceable current measurements. This paper examines the difficulties encountered when making accurate current measurements using dc resistance shunts at currents up to 300 A. The advantages in stabilization time, stability and reduced uncertainties when making current measurements using a direct current comparator transformer (DCCT) are then discussed.

Dc Current Measurement using a Standard Shunt Resistor

The accurate measurement of dc current at values of 1 A and above is challenging. When using a traditional style meter, the uncertainties increase significantly even with an 8 ½ digit meter as the current approaches 1 A. Current clamps, Hall sensors and AMR sensors allow for the measurement of higher currents but with more significant uncertainties. Traditionally the use of high-current, low-resistance shunts have been used to measure large unknown currents. By measuring the voltage drop across a resistive shunt and knowing the value of the shunt, the current is calculated using Ohm's law. The accuracy of such a measurement is largely dependant upon having a thorough understanding of the characteristics of the resistive shunt?

All current measurements made using a standard shunt require the shunt to be calibrated and the calibration to be traceable to the System International (SI). The conditions under which the shunt will be used should be duplicated at the time of calibration. If the current shunt is used to measure multiple currents, for example, 5 %, 30 %, 50 %, and 70 % of the standard maximum current, the shunt should be calibrated at all four measurement currents. All resistors exhibit a power coefficient; which can be very small in some cases, but this is not generally the case for current shunts.

Figure 1 shows the current dependence of a 0.001 Ω shunt being measured at two different currents; 100 A and 300 A. The difference between the two measurement currents is approximately 40×10^{-6} . For accurate current measurements, this change in value must be considered. This raises the obvious question: is change in value linear between the two currents? To determine the linearity between two measurement currents requires more measurements be made at values between the two currents of interest. Much effort is required to understand the actual effects of a shunt's power coefficient since much of the change observed is associated to the temperature coefficient.

All standard resistors have a temperature coefficient. The effect is minimal for some standards, such as Evanohm® 1 Ω resistors. Current shunts, instead, have a significant temperature coefficient. The self-heating effect is easily observed when current is first applied to a shunt. Consequently, one must wait to reach a state of equilibrium. At this point, the shunt is generally referred to as having reached stability.

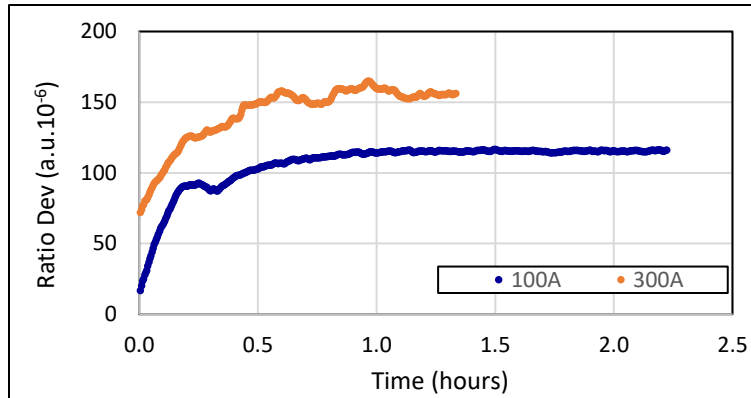

Figure 1. Measured values of a 0.001 Ω resistive shunt at 100 A (blue curve) and 300 A (orange curve) vs a 1 Ω standard resistor. The measurement setup and environmental condition are equivalent in both measurements.

Figure 2 illustrates this effect, where a 0.001 Ω , 300 A shunt is measured using a 100 A measurement current. The shunt is measured at room temperature three separate times with a two-hour delay between measurements. The shunt takes approximately 1.5 hours to reach stability, and its value changes by more than 60×10^{-6} over the same time. After applying the current for approximately 2 hours, all three measurements agree.

In Figure 3 the scale has been changed to highlight the agreement between the three measurements. Although Run2 (orange) was shorter, it looks consistent with Run1 (blue). However, Run3 (green) behaves differently from the other two measurements, this is believed to be due to environmental conditions. Nevertheless, Run3 approaches the same equilibrium as Run1.

It should also be noted that even after reaching stability, the value of the shunt continues to vary by approximately 3×10^{-6} . This raises the question, will the shunt behave the same way if the room temperature is different from the room temperature during calibration?

Standard resistors are often maintained in air and oil baths to provide a stable environment and greatly reduce the effects of the temperature coefficient. Due to the power dissipated by a high current shunt, running a shunt in an air bath is of no use, as it will overpower the air bath's ability to regulate the temperature. Using an oil bath presents similar challenges, but the effects of the shunt's power dissipation are reduced. Choosing to calibrate a shunt in an oil bath is only of value if the end user is also using the shunt with an oil bath.

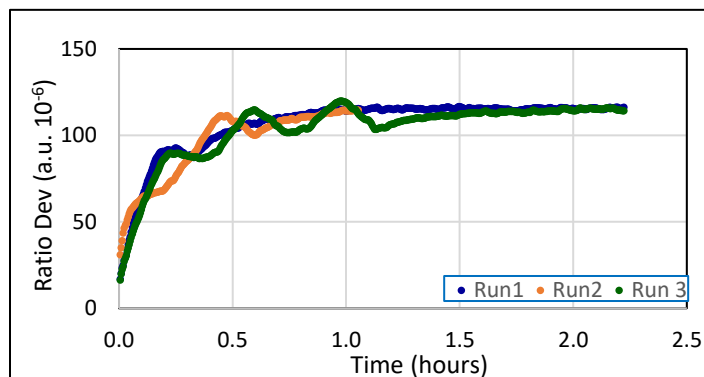

Figure 2. Measurement of a standard 0.001 Ω shunt vs. a 1 Ω standard resistor, with a measurement current of 100 A and a 2 hour wait between runs.

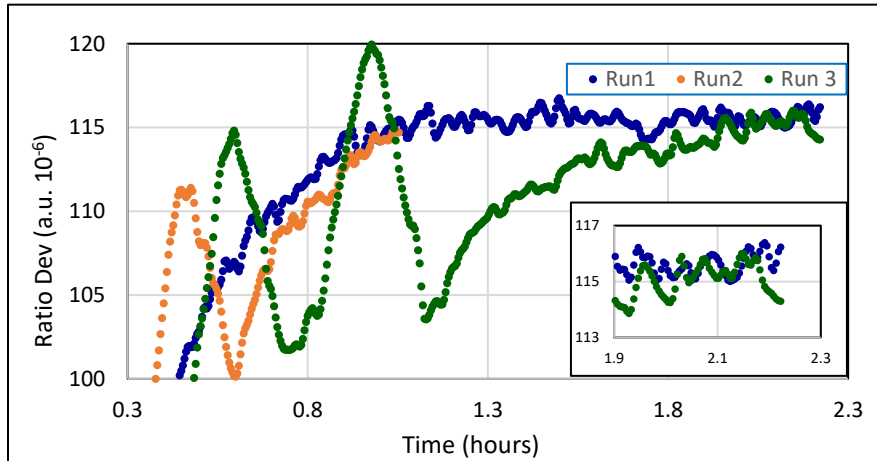

Figure 3. Three measurements of a standard 0.001 Ω shunt with a measurement current of 100 A. The inset is a zoomed-in view of the last 18 minutes of the measurement.

Standard resistors drift over time. The drift tends to be linear, but this is not always the case. Multiple measurements over time are required to calculate an accurate drift rate. Using the drift rate, the value of the current shunt can be projected to the date of use. The uncertainty associated with the projection will need to be included in the uncertainty budget. If these added calculations prove impractical, an uncertainty component for the drift will need to be added to the uncertainty budget.

Along with the shunt's calibration uncertainty, the uncertainties due to current dependence, the temperature coefficient of the shunt, the shunt's drift, and the repeatability of the measurement need to be included in the uncertainty budget when measuring an unknown current. These uncertainty components are often much larger than the calibration uncertainty.

Measuring Dc Current below 100 mA

With the advent of quantum voltage (PJVS) and resistance standards (QHR), the calibration uncertainties dc Zeners and standard resistors are now below 1×10^{-6} . Very accurate measurements of dc current below 100 mA should be achievable using a calibrated standard resistor and an accurate digital multi-meter (DMM). At low current levels, the problems that arise when using current shunts, while still present, are very much reduced or become so small as to be inconsequential. If unknown currents above 1 A could be accurately divided to a lower level, the high currents could be measured with greater accuracy. The uncertainty of the measurement would become dependant upon the accuracy of the current division.

Direct Current Current Transformer (DCCT)

The DCCT is a complex 1:100 and 1:1000 transformer. By the nature of design, a DCCT will not have a temperature or current dependence. The division of current is based on transformer turns, and these turns will not change over time, thus, there will be no drift over time. The advantages over a dc current shunt appear to be obvious.

Combining multiple DCCTs enables the measurement of currents of several thousand Amperes. For instance, a MI 6314A can be used to divide up to 3000 A by 1000 (3 A maximum output), which can be



Figure 4. A Measurements International 6311A Precision Current Divider (or DCCT) and four standard resistors

further divided by 100 using a 6311A (30 mA maximum output). In this way, a 1 Ω standard resistor and an 8½ digit DMM can be used to measure 3000 A with uncertainties of a few ppm.

In the following measurements a DCCT (MI 6311A) is connected to a high current shunt measurement system in a manner as to emulate a resistive shunt. The DCCT output current is connected to the current terminals of a standard resistor (R_{DCCT}) Figure 5. The measurement system includes a DCC bridge, a range extender, and a current source. The DCCT input current is supplied by the range extender and the output voltage of the R_{DCCT} is connected to the dcc bridge.

The input current applied to the DCCT ranged from 100 A to 300 A, this corresponds to a DCCT output current variation from 100 mA to 300 mA. By selecting different values of standard resistors (R_{DCCT}) based on the DCCT output current, the DCCT emulated shunt values of 0.001 Ω and 0.0001 Ω . The resulting measurements provide the ratio between the DCCT and a known standard resistor R_s connected to the R_s terminals of the DCC bridge.

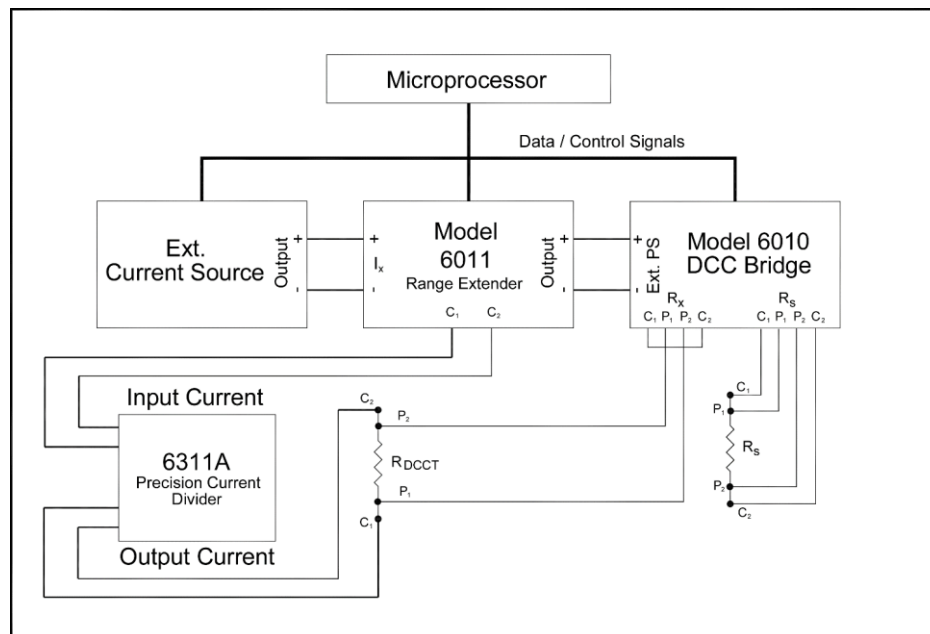

Figure 5. Block schematic of the DCCT connections to a MI High Current Resistance Measurement System.

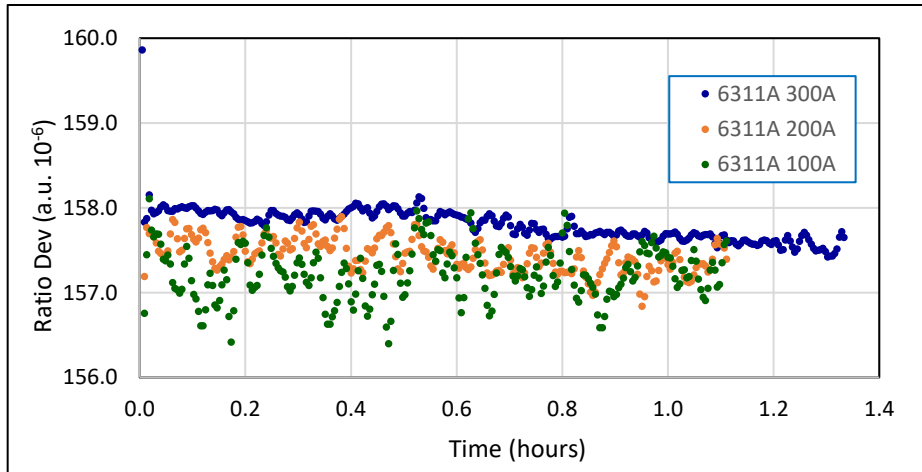

Figure 6. Measurement of the 6311A emulation of a resistance shunt at 100 A, 200 A and 300 A with an R_{DCCT} of 0.1Ω .

Figure 6 illustrates how the 6311A has no current dependency. For this measurement the same R_s and R_{DCCT} were used for all three measurements. The slight difference in ratio observed between the three measurements are believed to be caused by the power coefficient of R_{DCCT} . The data also illustrates how the current measurement is stable almost as soon as the current is applied.

Figure 7 shows the repeatability and stability of the 6311A with a measurement current of 100 A. Each measurement is more than two hours and in each case no warm-up time is required. The R_{DCCT} , for these measurements is a 1Ω resistor rather than the 0.1Ω resistor used in the previous measurement (result in Figure 6), resulting in a different ratio deviation. When measuring a current of 100 A, the DCCT behaves much like a standard resistor rather than a high current shunt.

Table 1 lists, for each input current, the expected 6311A output current, and the ideal standard resistor to minimize the measurement uncertainty. This enables to user to emulate a resistive shunt from values of 0.1Ω to 0.0001Ω .

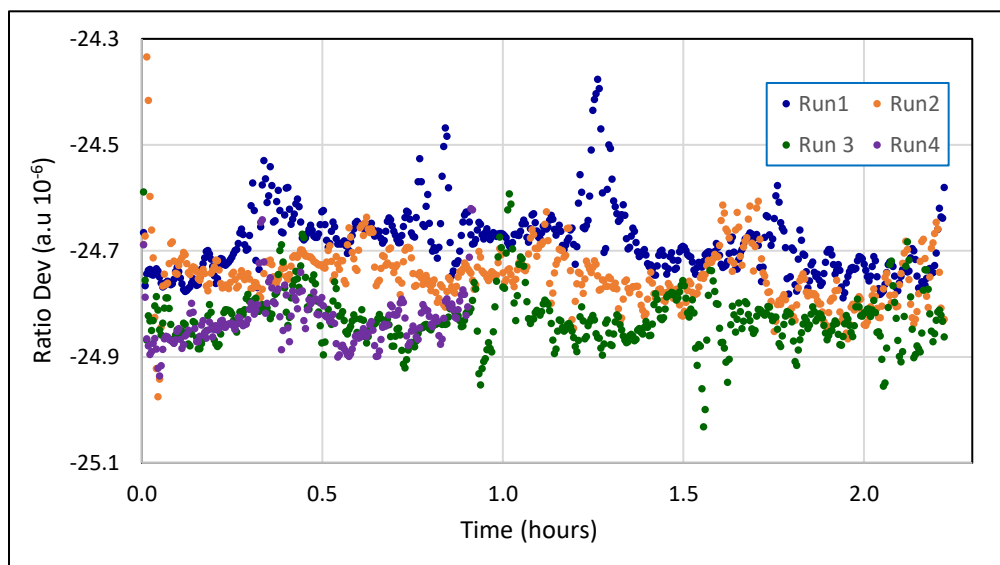

Figure 7. Measurement of the 6311A as a 0.001Ω resistance shunt at 100 A. The measurement was repeated four time without delay between runs.

Table 1. DCCT current measurement ranges using various R_{DCCT}

CURRENT INPUT (A)	CURRENT OUTPUT (mA)	RS (Ω)	OUTPUT VOLTAGE (mV)
10 A Range			
1	10	10 or 1	100 or 10
5	50	1 or 0.1	50 or 5
10	100	1 or 0.1	100 or 10
300 A Range			
10	10	10 or 1	100 or 10
50	50	1 or 0.1	50 or 5
100	100	1 or 0.1	100 or 10
200	200	1 or 0.1	200 or 20
300	300	1 or 0.1	300 or 30

Calibration of a Direct Current Current Transformer (DCCT)

The calibration of the 6311A is required to determine what the offset is from exactly 1:1000 and 1:100. When a standard resistor is connected to the output current of the DCCT, the DCCT will act exactly like a current shunt, see Figure 8.

The shunt equivalent value of the 6311A is:

$$R_{SEq} = \frac{E_{DCCT}}{\left(\frac{I_{IN}}{r_{NOM}}\right)} \times \frac{1}{r_{NOM}} = \frac{R_{DCCT}}{r_{NOM}}$$

where: R_{DCCT} is the value of standard resistor connected to the DCCT in Ω

R_{SEq} is shunt equivalent value in Ω

E_{DCCT} is the voltage measured across the standard resistor R_{DCCT} in V

I_{IN} is the current applied to the DCCT in A

r_{NOM} is the comparator ratio.

Therefore, the ratio of the DCCT is:

$$r_{NOM} = \frac{R_{DCCT}}{R_{SEq}}$$

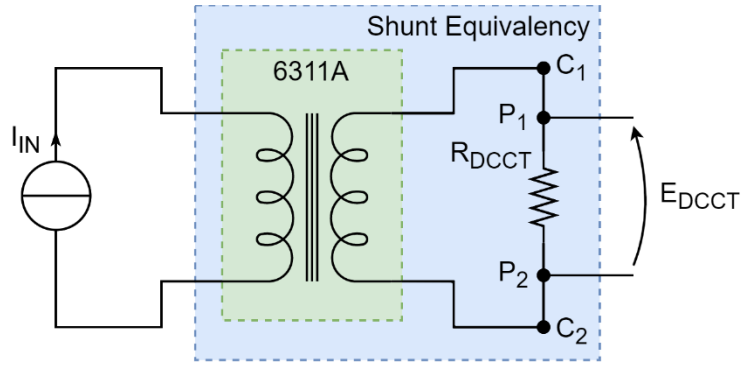

Figure 8. Block schematic of a DCCT as a current shunt.

Where the R_{DCCT} is given by the calibration of the standard resistance and R_{SEq} is measured with a high current measurement system.

The deviation from the nominal ratio is:

$$\Delta r = \frac{r_{NOM} - r_{DCCT}}{r_{NOM}} = 1 - \frac{1}{r_{NOM}} \frac{R_{DCCT}}{R_{SEq}}$$

The calibration of the DCCT just described has an accuracy of about ten fold compared to the calibration of the shunt resistor.

For example, MI is accredited to calibrate 1Ω resistors with an uncertainty of 0.1×10^{-6} and 0.001Ω shunts with an uncertainty of 0.9×10^{-6} . The calibration of a DCCT as a 0.001Ω shunt, carried out at 100 A, is shown in Figure 9, where one can see the low scatter of the points.

Using the DCCT to Measure Dc Current

A DCCT provides a solution for improving the accuracy of dc current measurements. The DCCT does not suffer from the shortcomings found with dc resistance shunts, is easy to calibrate and is uncomplicated to use. The current can be measured directly at the output of the 6311A using a variety of DMM's. The measured current is multiplied by the calibrated ratio value for the 6311A, which equals the input current. The output current can be applied to a standard resistor for more accurate measurements. By measuring the voltage across the resistor and knowing the value of the resistor, the current is calculated using Ohm's law and then multiplied by the calibrated ratio of the 6311A.

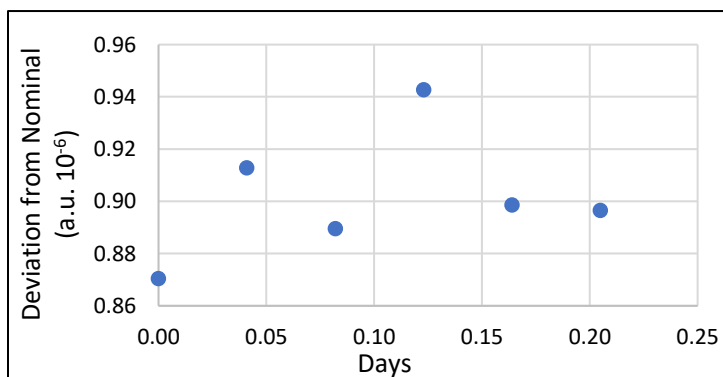

Figure 9. Six data points of a 6311A's calibration using a 100 A measurement current.